

COMBINATION SOAP/PAPER/WASTE WP5710



448 x 1348 x 320 mm

950 ml soap, 750 paper towels, 72 l waste bin

- Combination consisting of a liquid soap dispenser, a paper towel dispenser and a waste bin in robust, germ-reducing and easy-care stainless steel (AISI 304).
- All-stainless steel housing; all corners fully welded, visible surfaces satin finished and brushed. Further available surfaces: see below.
- Liquid soap dispenser with one-hand operated and non-drip soap pump.
- Designed for standard 950 ml disposable bottles of liquid soap or hand lotion.
- Also available as sensor soap dispenser for a surcharge.
- Paper towel dispenser with deep-drawn paper removal opening for easy paper removal.
- Designed for approx. 750 standard paper towels in zigzag fold.
Paper size (folded): 240-250 mm x 100-115 mm.
- Inspection slots to indicate fill level.
- Accessible for refilling through lockable door.
- Waste bin equipped with removable mesh basket. Capacity approx. 72 l. Accessible through front flap.
- Keyed alike cylinder lock in corrosion-resistant zinc die-casting.
- Wear parts and front panels can be replaced as modules.
- Installation dimensions: 450 x 1350 x 210 mm (when fully fitted).
- Mounting: With six screws in wall opening through fixing holes in the side walls.
- Delivery includes fixing material, first fill with soap and one pack of paper towels.
- Weight, including single package: 26.7 kg



Suggested text for specifications:

Combination consisting of a liquid soap dispenser, a paper towel dispenser and a waste bin in stainless steel (AISI 304) for flush mounting. All-stainless steel housing; all corners fully welded, visible surfaces satin finished and brushed. Liquid soap dispenser with one-hand operated and non-drip soap pump. Designed for standard 950 ml disposable bottles of liquid soap or hand lotion. Paper towel dispenser with deep-drawn paper removal opening, filling quantity approx. 750 paper towels. Inspection slots to indicate fill level. Accessible for refilling through lockable door. Waste bin equipped with removable mesh basket. Capacity approx. 72 l. Accessible through front flap. Keyed alike cylinder lock in corrosion-resistant zinc die-casting. Delivery includes fixing material, first fill with soap and one pack of paper towels.

Dimensions: 448 x 1348 x 320 mm

Article No. WP5710

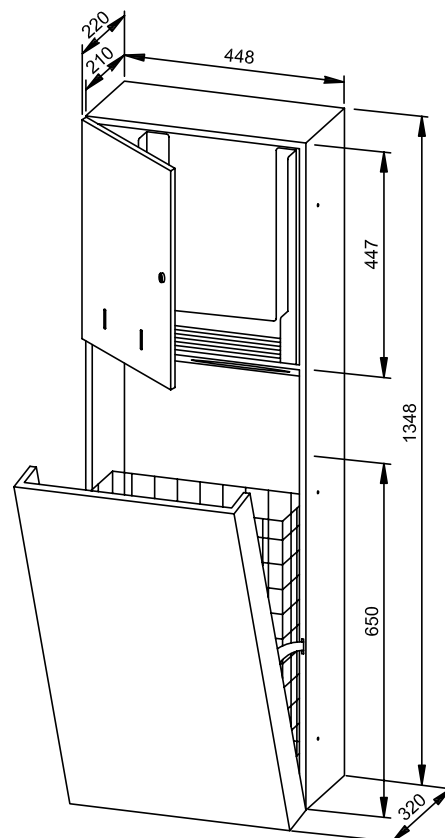

Available surfaces	ID No.
satin finished (standard)	727 542
highly polished	731 542
(coloured) plastic powder-coating	728 542

Ernst Wagner GmbH & Co. KG

Ernst-Abbe-Straße 21 · D-72770 Reutlingen · Tel.: +49712151539-0 · Fax: -20
info@wagner-ewar.de · www.wagner-ewar.de

WAGNER
EWAR